



**REGISTER
YOUR WARRANTY
ONLINE AT
www.sanuvox.com**

SR MAX WHOLE HOME UV AIR PURIFIER Residential Model

⚠️ **IMPORTANT SAFETY INSTRUCTIONS** ⚠️

READ AND SAVE THESE SAFETY INSTRUCTIONS BEFORE USING THIS PRODUCT.

Read and follow all instructions contained in the manual before using the product. Read the maintenance instructions before opening the UV unit or system. Failure to comply with these instructions may result in injuries or damage to the UV unit or system.

⚠️ NEVER EXPOSE EYES OR SKIN TO AN OPERATING UV LAMP. ⚠️

1. **Installation and servicing** of UV units or systems (in an air conditioning system or not) **can be hazardous. Only trained and qualified service personnel** should install, repair or service equipment.
2. **Untrained personnel** can perform **basic maintenance** functions such as replacing lamp(s) and/or filter(s). All other operations should be performed by trained service personnel.
3. The unit is not to be used by persons (including children) with reduced physical, sensory or mental capabilities, or lack of experience and knowledge.
 ⚠️ **CAUTION:** Unit is not a toy. Keep away from unsupervised children. Do not leave children unattended with the unit.
4. **DO NOT hang onto the UV unit or system.**
5. Some UV units or systems could be heavy: Make sure you have a minimum of 2 people to safely move or install these UV units or systems, and make sure you adopt the most ergonomic position possible (use UV unit or system handles, if applicable).
 ⚠️ **CAUTION:** Installing or maintaining heavy equipment, especially overhead, can cause back pain or other injuries.
6. When installing or servicing an overhead UV unit or system, be careful not to fall off the stepladder. Furthermore, make sure the UV unit or system latches are always in place to prevent falling parts.
 ⚠️ **CAUTION:** Some parts of some UV units and systems may open suddenly if the UV unit or system is installed high up without its locks.
7. Units that are obviously damaged must not be operated.
8. ⚠️ **CAUTION:** When working on the UV unit or system, observe precautions on the literature, tags and labels attached to the UV unit or system, and all other safety precautions considered as best practices in the HVAC industry, if applicable.
9. When applicable, local regulation may comprise more restrictive installation and/or certification requirements. The aforementioned requirements prevail on those of this document and the installer agree to conform to these at his own expense.
10. Follow all the safety instructions outlined in this document and respect all local and national codes applicable.
11. All UV units or systems contain a UV-C source. Damage to the housing or unintended use of the UV unit or system may result in harmful UV-C leaks. UV-C may, even in little doses, cause harm to the eyes and skin.
12. **Never expose eyes or skin to an operating UV lamp.** Therefore, **before installing or performing maintenance** on the UV unit or system, **TURN OFF AND DISCONNECT** the UV unit or system **from all power sources** (there may be more than one switch to disconnect) and also disconnect the HVAC system, is applicable.
 ⚠️ **CAUTION:** Electrical shock may cause injuries or possibly death. **FIRST AID INSTRUCTIONS:** If injured, consult a doctor.
13. UV rays may damage certain types of filters (polymer or plastic); please keep the UV unit or system light away from shining directly on plastic.
14. When installing or performing maintenance on the UV unit or system, it is recommended to **wear safety gloves**. In order to avoid reduced performance of lamp(s), **do not touch lamp glass without gloves**.
15. Just like conventional fluorescent lamps, UV lamps contain a small quantity of mercury: if a lamp breaks, clean and **dispose of with care**. UV lamps can be disposed/recycled after use in the same way as any other fluorescent lamps. Contact and follow the specific instructions of your local and national authorities.
16. **Use only specified SANUVOX branded replacement UV lamps for your UV unit or system.** Use of any other lamps will void your warranty and can result in damage to the UV unit or system.
17. Sanuvox UV units or systems are not waterproof. **DO NOT INSTALL OUTDOORS OR IN WET LOCATION** unless specified otherwise.
18. The use of a UV unit or system is a supplement to and not a substitute for standard infection control practices; users must continue to follow all current infection control practices, including those related to the cleaning and disinfection of environmental surfaces.

SAVE THESE INSTRUCTIONS

For any inquiries on a UV unit or system, contact:
Robert Smith
 146 Barr St, Saint-Laurent
 Quebec, CA, H4T 1Y4
 1-888-726-8869
techsupport@sanuvox.com

Installation Date: _____ Installed by: _____

Installer Contact Info.: _____

TABLE OF CONTENTS

△ IMPORTANT SAFETY INSTRUCTIONS △	1
TABLE OF CONTENTS	2
ABOUT THE PRODUCT	3
COMPONENTS	3
How it Works	3
SETUP & INSTALLATION	4
What you will need	4
What's included	4
Step by Step Setup & Installation	4
OPERATION	7
How to Operate your Product	7
How to Read the LED Status Display	7
How to Activate "Airflow Detection" Function (Optional)	8
Step by Step Function Activation	8
How to Reset your Product and its Lamp Timer	9
Step by Step Product and Lamp Timer Reset	9
MAINTENANCE	10
How to Replace Lamp(s)	10
Step by Step Lamp Replacement	10
How to Clean your Product	12
STORAGE	12
ULTRAVIOLETS: UVC	12
ELECTRICAL RATINGS, POWER CONSUMPTION & AVAILABLE VOLTAGE	12
TROUBLESHOOTING	12
What you will need	12
Internal Components	12
Problems & Solutions Table	13
A. Step by Step SR Max Ballast Box Opening	14
B. Step by Step UV Lamp Continuity Test	14
C. Step by Step LED Display Circuit Board Bypass (Ballast or Circuit Board Validation)	15
D. Step by Step Thermistor Deactivation	15
WARRANTY	16
CUSTOMER SERVICE	16

ABOUT THE PRODUCT

The SR Max represents an evolution in whole home UV air purification. The high-efficiency patented design helps reduce airborne biological contaminants, while providing important user information with its LED status display. Installed into the return or supply plenum, the Sanuvox proprietary process maximizes dwell (contact) time between the air and UV energy. With the ability to treat homes up to 2,000 sq.ft., the patented technology rapidly purifies the air and removes odors within the home.

For information or recommendations on how to size your specific application, please call SANUVOX at 1-888-726-8869.

COMPONENTS

How it Works

Contaminated air enters the SR Max parallel to the UV 'J' Lamp, thus increasing contact time with the UV energy. The Turbulator spins and mixes the air around the UV 'J' Lamp. The UVC germicidal lamp helps reduce the biological contaminants. The Aluminum Reflector Chamber coated with cobalt amplifies the UV energy for optimal purification. Finally, the treated air circulates through the home.

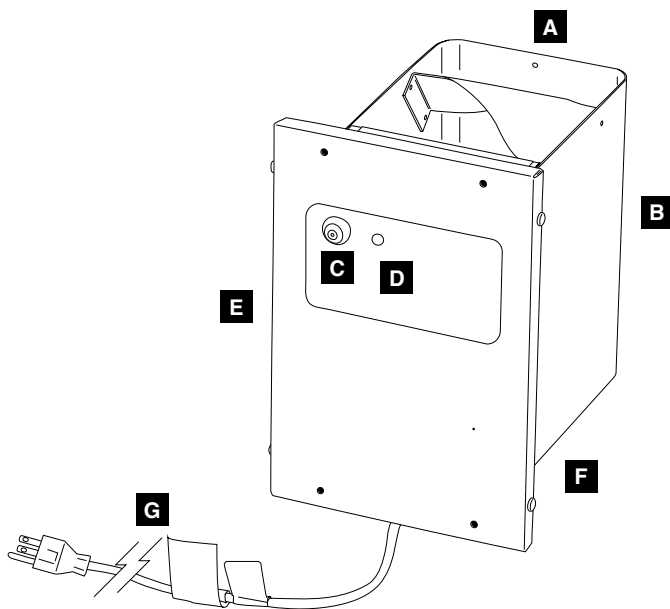

- A. Turbulator & Air Inlet
- B. Aluminum Chamber coated with cobalt (UV Lamp inside)
- C. Power Switch
- D. LED Status Display
- E. Cover
- F. Air Outlet
- G. Power Cord

SETUP & INSTALLATION

What you will need

A utility knife to unpack all components, a Phillips No.2 screwdriver or a drill, a measuring tape, a marker and a metal saw.

⚠ CAUTION: Handle your product with care to avoid breaking parts. Make sure you have a free and safe space to unpack, install and setup your product. Confirm you have access to the necessary power source for the product requirements (see unit or system label). If you have any questions regarding the installation instructions, call SANUVOX at 1-888-726-8869.

What's included

The SR Max with its turbulator, a UV lamp and a basic installation kit.

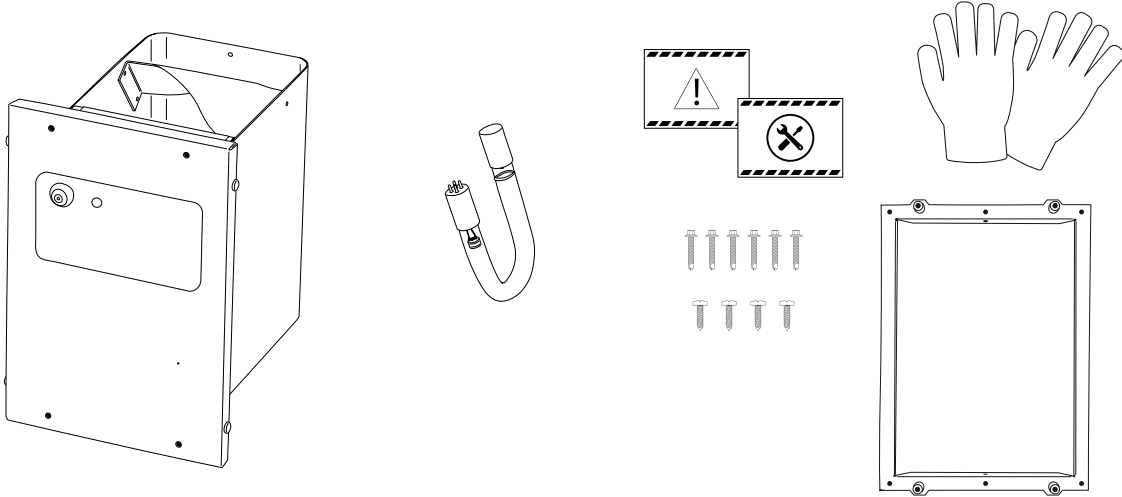

The installation kit includes: a UV caution decal, a maintenance decal, a pair of cotton gloves, metal screws for frame (6), Phillips screws for cover (4) and a frame.

Step by Step Setup & Installation

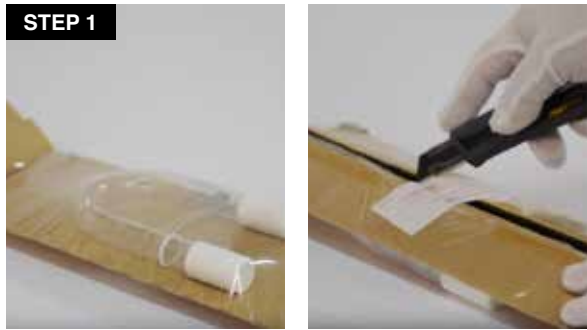

1. **Prepare the SR Max for installation.** Remove the contents from packaging. Only after you have visually inspected the UV lamp should you break the security seal on the underside of the cardboard sleeve.

⚠ CAUTION: Before installing or performing maintenance on the unit or system, **TURN OFF AND DISCONNECT the unit or system from all power sources** (there may be more than one switch to disconnect).



2. Carefully slide the **UV lamp** out from the cardboard sleeve. Be sure to wear the **cotton gloves** (included) guaranteeing a clean lamp free from fingerprints.

NOTE: Fingerprints on the lamp will negatively impact the UV output of the lamp.



- To install the UV lamp, release the reflecting tube by removing the 2 screws on each side.



- While holding the porcelain end-cap (with 4 pins), carefully push the white connector onto the four pins. The plug is designed so that it can only be installed one way. You may have to rotate the socket 90° to line up the pins with the holes. The connector will fit into position.

NOTE: Too much force applied from the opposite end-cap may break the lamp.



- Slide the **UV lamp porcelain end-cap (with 4 pins)** through the clamp. Once the UV lamp is inserted, release the clamp to fix the lamp in place.

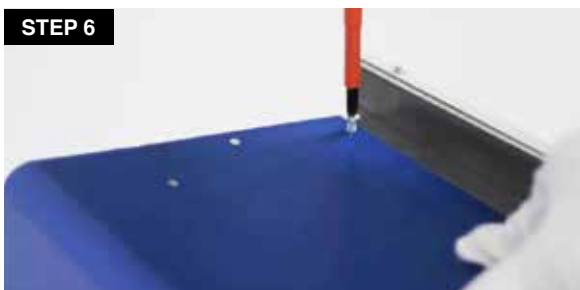

- Once the UV lamp is installed, reinstall the reflecting tube. It is important to note that the air should first flow through the turbulator before moving in front of the UV lamp.



- Prepare the duct (return or supply) for installation. Evaluate the ideal area for installing the air purifier. **The reflection chamber should always be parallel* to the airflow.** Ensure that the purifier will fit into the plenum and position it keeping in mind to minimize plastic exposure to direct UV light.

⚠ CAUTION: Before installing or performing maintenance on the unit or system, **TURN OFF AND DISCONNECT the unit or system from all power sources** (there may be more than one switch to disconnect).

*The reflecting chamber that houses the UV lamp may be rotated 180°, allowing for the control box to be vertical in almost any situation. So the turbulator, reflecting chamber and lamp face the airflow (i.e. horizontal or upflow airflow). To rotate the reflecting chamber and UV lamp, remove the front cover, then the two Philips screws in the center of the housing (just above the hex nut). This allows for the reflecting chamber and UV lamp to be easily rotated. Refasten screws once the desired orientation is found. Replace cover.



- Use the included metal frame to trace the outline onto the duct. Allow for a 1/8" space around the marking as to allow the frame to sit properly in the duct. The duct opening window should have the following dimensions: 8.5" x 5.5".



- Place the frame into the opening made in the duct and use the 6 metal screws provided in the installation kit to secure it in place. Use preferably 3 top and 3 bottom holes of the frame to insert the screws.



- Finalize the SR Max installation in the duct by placing the unit into the frame, guided with the alignment pins.



- Secure the SR Max to the frame with the 4 remaining screws located in the 4 corners of the SR Max cover.



- Use the power cord of the unit to plug into a wall outlet that provides the power, as indicated on the marking label of the product. An extension cord may be used if there is not a power outlet close to where the SR Max is installed.

Then wait for one minute before turning on the unit.

You are now ready to power ON your new SR Max and enjoy great air quality for you and your family.

OPERATION

How to Operate your Product

The SR Max is an automatic unit: once it's installed and plugged in, simply press the power switch to turn it ON. Wait approximately 40 seconds for the startup phase to be done and enjoy clean air in your home!

⚠ **CAUTION:** The suggested operating temperature range is 10 to 50°C (50 to 122°F). Operating the SR Max outside this range will result in decreased performance. For optimal performance, air temperature moving through the reaction chamber should be in the range of 15 to 20°C (60 to 70°F).

How to Read the LED Status Display

The SR Max's LED Status Display will give you real time status update about your unit and its lamp.

Normal Operation

- **GREEN:** In operation, "Default Mode".
- **ORANGE (Heartbeat followed by 1 flash):** Lamp over 3 years that needs to be replaced.
- **BLUE (Heartbeat):** Stand-by, waiting for airflow if "Airflow Detection" is activated*.

At Start-Up

- **BLUE:** Airflow detection activated*.
- **WHITE:** Factory setting, airflow detection de-activated.

Error Code**

- **RED (2 flashes):** Lamp or ballast failure.
- **RED (3 flashes):** Thermistor disconnected, if thermistor is activated.
- **RED (4 flashes):** Thermistor shorted, if thermistor is activated.

* Refer to the step by step instructions of the "Airflow Detection" Function Activation on page 8.

** Refer to the troubleshooting guide on page 12.

How to Activate “Airflow Detection” Function (Optional)

In “Default Mode” (power is ON and unit operates normally), the SR Max lamp is always lit. If you activate the “Airflow Detection” function, the thermistor will detect airflow and automatically turn the lamp ON or OFF as needed.

NOTE: This function is only for a certain type of HVAC furnace. When used on HVAC units with variable speed fans, this function may cause strain on the lamp or even premature lamp failure. Your installer should know which mode is right for your unit.

Step by Step Function Activation



1. If your unit is powered ON, start by turning OFF the power switch.



2. Use a small object similar to a paper clip and insert it into the reset hole in order to be able to press the reset button.



3. First turn ON the power switch and then, press the reset button. You have 5 seconds from the moment the unit is powered to press the reset button to activate the airflow detection. Every time you press the button you will notice that the LED color will either be “Blue” or “White”. Once the LED is “Blue”, wait 5 seconds while holding the reset button for the control circuit to save the setting.



4. From now on, the SR Max will only activate the lamp when the thermistor detects airflow in your duct system.

NOTE: The unit software is programmed to keep the lamp ON for 10 minutes after the airflow has completely stopped.

How to Reset your Product and its Lamp Timer

After installing a new lamp, make sure the timer function is reset.

Step by Step Product and Lamp Timer Reset



1. To reset the lamp timer the unit needs to be powered and turned ON. The status LED should either be "Green" or "Blue" (heartbeat).



2. Use a small object similar to a paper clip and insert it into the hole in order to be able to press the reset button.



3. Press and hold the reset button for a minimum of 3 seconds. When releasing the reset button, the counter will be reset to 1096 days.

MAINTENANCE**How to Replace Lamp(s)**

Replacing lamps on the SR Max is quick and easy. Simply turn off the power source, remove unit from duct, remove and dispose of old lamp, replace with new Sanuvox branded UV lamp, replace unit in duct and turn power source back on. See below for detailed step by step instructions.

⚠ **CAUTION:** In order to avoid reduced performance of lamp(s), do not touch lamp glass without gloves.

Step by Step Lamp Replacement

1. Take the SR Max out from the ductwork by removing the 4 screws located on the cover (4 corners) that hold it to the frame.



2. Release the reflecting tube by removing the 2 screws on each side to access the lamp.



3. Remove the old UV lamp from the lamp socket by opening the retaining clamp and pulling the UV lamp out.

NOTE: UV lamps can be disposed/recycled after use, as any other fluorescent lamps. Contact and follow your local and national authorities' specific instructions.

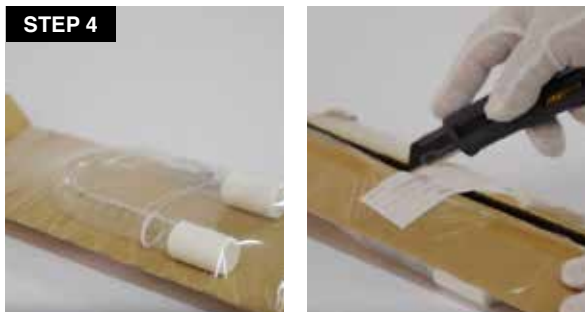

4. **Prepare the new lamp.** Remove the contents from packaging. Only after you have visually inspected the UV lamp should you break the security seal on the underside of the cardboard sleeve.

STEP 5



5. Carefully slide the new **UV lamp** out from the cardboard sleeve. Be sure to wear the **cotton gloves** (included) guaranteeing a clean lamp free from fingerprints. Fingerprints on the lamp will negatively impact the UV output of the lamp.

STEP 6



6. While holding the porcelain end-cap (with 4 pins), carefully push the white connector onto the four pins. The plug is designed so that it can only be installed one way. You may have to rotate the socket 90° to line up the pins with the holes. The connector will fit into position.

NOTE: Too much force applied from the opposite end-cap may break the lamp.

STEP 7



7. Slide the **UV lamp porcelain end-cap (with 4 pins)** through the clamp. Once the UV lamp is inserted, release the clamp to fix the lamp in place.

STEP 8

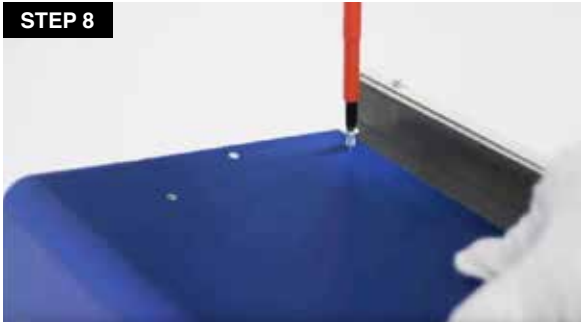

8. Once the UV lamp is installed, reinstall the reflecting tube. It is important to note that the air should first flow through the turbulator before moving in front of the UV lamp.

STEP 9



9. Once the new UV lamp is installed, replace the SR Max into duct. Then, reset your product and its lamp timer (see page 9).

How to Clean your Product

For optimal performance, the lamp(s) and reflecting chamber should be kept free of dust and residue deposit. Clean when necessary with mild soap or alcohol. Always spot test the cleaner to make sure it does not damage the surface.

⚠ **CAUTION:** Under no circumstance should water be sprayed or splashed onto the product.

STORAGE

The SR Max is an in-duct unit working continuously and automatically and therefore, requires no specific storage.

ULTRAVIOLETS: UVC

The UVC (254 nm) wavelengths produced by Sanuvox UV units and systems are the same as the ultraviolets produced by the Sun. The UVC attacks the micro-organisms on a molecular level deactivating the contaminants. Unlike conventional UV lamps on the market, Sanuvox UV units and systems use a patented process designed to deliver the maximum UV dosage to the moving airstream or surface.

⚠ **CAUTION:** Never expose eyes or skin to an operating UV lamp.

ELECTRICAL RATINGS, POWER CONSUMPTION & AVAILABLE VOLTAGE

The product is rated at 120/240 VAC, 50/60 Hz and 48 W.

See product label to confirm power consumption of your specific unit or system.

NOTE: IF YOU EXPERIENCE A PROBLEM, PLEASE CONTACT CUSTOMER SERVICE FIRST OR SEE YOUR WARRANTY. DO NOT RETURN THE PRODUCT TO THE ORIGINAL PLACE OF PURCHASE. DO NOT ATTEMPT TO OPEN THE PRODUCT OR TAMPER WITH ITS COMPONENTS WITHOUT CONTACTING CUSTOMER SERVICE FIRST. DOING SO MAY VOID YOUR WARRANTY AND CAUSE PERSONAL INJURY OR DAMAGE TO THE PRODUCT.

TROUBLESHOOTING

If your product is not working properly, refer to the following.

What you will need

A Phillips No. 2 screwdriver, an ohmmeter and a 5/16" nutdriver.

Internal Components

To access SR Max internal components, see step by step instructions of the **Ballast Box Opening on page 14 (A)**.

- A. Ballast
- B. Ballast to Lamp Connection
- C. Thermistor
- D. Circuit Board
- E. Circuit Board to Ballast Connection
- F. Reset Button

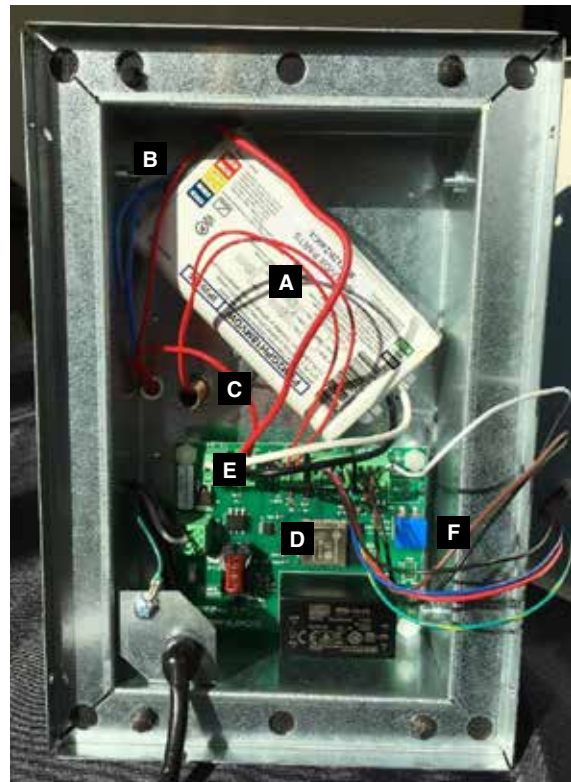

Problem	Possible Cause	Solution
On/Off button internal light is not lit.	<ul style="list-style-type: none"> - There is no power to the electrical outlet. - The On/Off switch is not ON. - Power cord is damaged. - LED display circuit board is damaged or defective. 	<ul style="list-style-type: none"> - Test the outlet to make sure there is power by plugging in another electrical appliance. - Turn the switch to the ON position. - Check the power cord for damage and replace if damaged. - Visually inspect the LED display circuit board and look for damage/burn marks.
Status LED is "ORANGE".	<ul style="list-style-type: none"> - The lamp has reached its 3 year lifespan. 	<ul style="list-style-type: none"> - Get a genuine replacement lamp and reset the counter to 3 years. <p>See Product and Lamp Timer Reset instructions on page 9.</p>
Status LED is "RED" with 2 flashes.	<ul style="list-style-type: none"> - Connection issues between the lamp and the ballast. - Connection issues between the ballast and circuit board (power supply). - Defective lamp. - Defective ballast. 	<ul style="list-style-type: none"> - Check connections to ballast and circuit board. - Check the wire connections at the ballast and at the lamp (plug). - Check lamp continuity. <p>See Ballast or Circuit Board Validation on page 15 (C).</p>
Status LED is "RED" with 3 flashes.	<ul style="list-style-type: none"> - Thermistor is not connected. - Thermistor is damaged or defective. 	<ul style="list-style-type: none"> - Check thermistor connections - Replace thermistor
Status LED is "RED" with 4 flashes.	<ul style="list-style-type: none"> - Thermistor is shorted. 	<ul style="list-style-type: none"> - Replace thermistor
Status LED is "BLUE" with heartbeat.	<ul style="list-style-type: none"> - Airflow detection activated, waiting for airflow. 	<ul style="list-style-type: none"> - Turn the fan ON or set a higher speed to increase airflow circulating in the ductwork. - Reposition the SR Max in the ductwork where the airflow is unobstructed. - If airflow is not sufficient to be detected by thermistor, remove airflow detection. <p>See Thermistor Deactivation instructions on page 15 (D).</p>
Status LED is off while the unit is powered on.	<ul style="list-style-type: none"> - Start-up not completed. - Defective LED. 	<ul style="list-style-type: none"> - Wait 5-10 seconds for start-up to complete. - Replace LED.
Lamp burnt before the elapsed 3 years, if thermistor is not activated (default settings).	<ul style="list-style-type: none"> - Defective lamp. 	<ul style="list-style-type: none"> - Get a genuine replacement lamp under warranty. <p>See Product and Lamp Timer Reset instructions on page 9.</p>
Lamp burnt before the elapsed 3 years, if thermistor is activated.	<ul style="list-style-type: none"> - Overcycling of the UV lamp due to excessive start/stop of the variable speed fan. 	<ul style="list-style-type: none"> - Deactivate thermistor. <p>See Thermistor Deactivation instructions on page 15 (D).</p>

Contact your contractor for all your needs in terms of replacement parts: power cord, circuit board, LED display, ballast, UV lamp, thermistor, etc.

A. Step by Step SR Max Ballast Box Opening



1. Take the SR Max out from the ductwork by removing the 4 screws located on the cover (4 corners) that hold it to the frame.



2. Place the SR Max on a flat surface and remove the 2 screws on each side that attach the cover to the ballast box.

B. Step by Step UV Lamp Continuity Test



1. Take the SR Max out from the ductwork by removing the 4 screws located on the cover (4 corners) that hold it to the frame



2. Release the reflecting tube by removing the 2 screws on each side to access the lamp. Then remove the UV lamp from the lamp socket by opening the retaining clamp and pulling the UV lamp out of the reflector chamber.



3. Using an ohmmeter place 1 probe on 1 of the 4 pins and by sensing the 3 remaining pins, one should have continuity. Make sure the 2 remaining pins also have continuity. When both sets of pins test good for continuity, it can be assumed that the lamp is good.

C. Step by Step LED Display Circuit Board Bypass (Ballast or Circuit Board Validation)

1. Open the SR Max ballast box : see step by step instructions of the **Ballast Box Opening on page 14 (A)**.

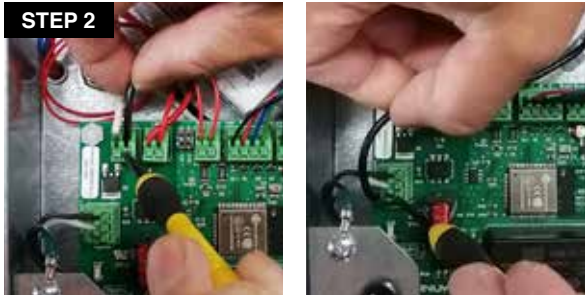

2. Unplug the ballast black wire from the circuit board. Insert that wire into the connector identified "Bypass".



3. Place the unit down and make sure you have no direct line of sight with the lamp. Plug the power cord.

The UV lamp should light up if both the lamp and ballast are still functional.

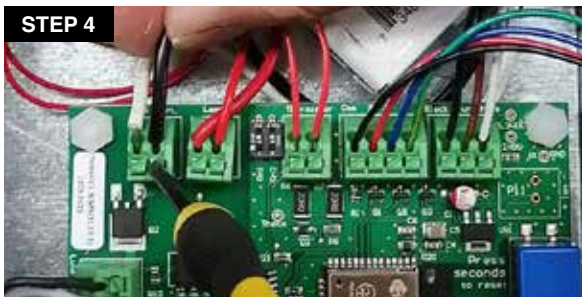

4. After the test is completed, unplug the unit and replace the black wire from the cord in its original position identified "Line".

D. Step by Step Thermistor Deactivation

1. Open the SR Max ballast box : see step by step instructions of the **Ballast Box Opening on page 14 (A)**.



2. Plug in the SR Max to a power source and turn ON the unit by pressing the power button. In the first 5 seconds from powering the unit ON, click the Reset button once. By doing so, you'll see the status LED turn Blue meaning the airflow detection is activated. By clicking again within 5 seconds, LED will turn White meaning that airflow detection is deactivated.

WARRANTY

You should first read all instructions before attempting to use this product. For this warranty to be valid, keep a copy of the proof of purchase.



UV lamp	3 years
Ballast	3 years
Electronic components	3 years

- A. This limited warranty applies to repair or replacement of product found to be defective in material or workmanship. This warranty does not apply to damage resulting from abusive, unreasonable use or supplemental damage. Defects that are the result of normal wear and tear will not be considered manufacturing defects under this warranty.
SANUVOX IS NOT LIABLE FOR INCIDENTAL OR CONSEQUENTIAL DAMAGES OF ANY NATURE, ANY IMPLIED WARRANTY OF MERCHANTABILITY OR FITNESS FOR A PARTICULAR PURPOSE ON THIS PRODUCT IS LIMITED IN DURATION TO THE DURATION OF THIS WARRANTY.
 Some jurisdictions **do not** allow the exclusion or limitation of incidental or consequential damages or limitation on how long an implied warranty last, so the above limitations or exclusions may not apply to you. This warranty gives specific legal rights, and you also may have other rights which vary from jurisdiction to jurisdiction. This warranty applies only to the original purchaser of this product from the original date of purchase.
- B. At its option, SANUVOX will repair or replace this product if it is found to be defective in material or workmanship.
- C. This warranty does not cover damage resulting from any unauthorized attempts to repair or from any use not in accordance with the instruction manual.
- D. This warranty does not cover the filters, pre-filters or other accessories (if included), except for material or workmanship defects.

Call us toll-free at 1-888-726-8869 or email: info@sanuvoy.com

Please be sure to specify product name.

NOTE: IF YOU EXPERIENCE A PROBLEM, PLEASE CONTACT CUSTOMER SERVICE FIRST OR SEE YOUR WARRANTY. DO NOT RETURN THE PRODUCT TO THE ORIGINAL PLACE OF PURCHASE. DO NOT ATTEMPT TO OPEN THE PRODUCT OR TAMPER WITH ITS COMPONENTS WITHOUT CONTACTING CUSTOMER SERVICE FIRST. DOING SO MAY VOID YOUR WARRANTY AND CAUSE PERSONAL INJURY OR DAMAGE TO THE PRODUCT.

CUSTOMER SERVICE

TO ORDER REPLACEMENT PARTS

PLEASE CONTACT YOUR CONTRACTOR OR SANUVOX CUSTOMER SERVICE

Toll-Free Phone #: 1-888-726-8869

Email: info@sanuvoy.com

Website: www.sanuvoy.com

Please be sure to specify product name.

Replacement parts for this product

BST120/240GL	Ballast with multi-voltage input of 120-277 VAC, 50/60 Hz
LMPRGJ65	T6 Regular (UVC) 6.5" 'J' shaped UV lamp
MSCELC20-1	Circuit Board
MSCTER2	Thermistor

⚠ WARNING: Use only specified SANUVOX branded replacement UV lamps with your unit or system. Use of any other lamps will void your warranty and can result in damage to the unit, system and/or lamp(s).